

## CA448 Compiler Construction 1 Repeat Examination Answers 2006

1.  $(b^*ab^*a)^*b^* \mid (a^*ba^*b)^*a^*ba^*$  [10 marks]

2. [10 marks]

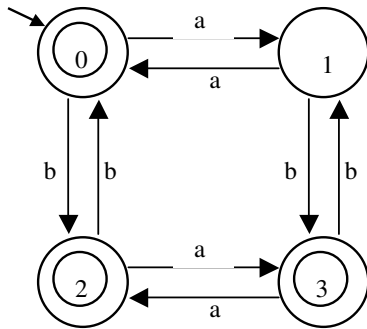

3. The two parse trees are as follows: [10 marks]

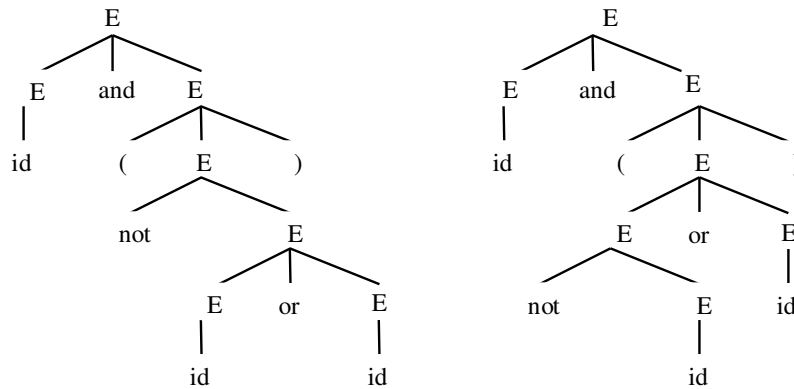

4. The equivalent grammar is as follows: [10 marks]

$$\begin{aligned}
 E &\rightarrow E \text{ or } T \mid T \\
 T &\rightarrow T \text{ and } F \mid F \\
 F &\rightarrow \text{not } F \mid (E) \mid \text{id}
 \end{aligned}$$

5.  $\text{LOOKAHEAD}(S \rightarrow aAa) = \text{FIRST}(a)$  [10 marks]

$$= \{a\}$$

$$\text{LOOKAHEAD}(S \rightarrow b) = \text{FIRST}(b)$$

$$= \{b\}$$

$$\text{LOOKAHEAD}(A \rightarrow ab) = \text{FIRST}(a)$$

$$= \{a\}$$

$$\text{LOOKAHEAD}(A \rightarrow \epsilon) = \text{FOLLOW}(A)$$

$$= \{a\}$$

The grammar is not LL(1) since a predicts both  $A \rightarrow ab$  and  $A \rightarrow \epsilon$

6. The following LR(0) items are produced for this grammar:

[10 marks]

- 1:  $S' \rightarrow \bullet S\$$ 
  - $S \rightarrow \bullet AaAb$
  - $S \rightarrow \bullet BbBa$
  - $A \rightarrow \bullet$
  - $B \rightarrow \bullet$
- 2:  $S' \rightarrow S\bullet\$$
- 3:  $S' \rightarrow S\$ \bullet$
- 4:  $S \rightarrow A\bullet aAb$
- 5:  $S \rightarrow B\bullet bBa$
- 6:  $S \rightarrow Aa\bullet Ab$ 
  - $A \rightarrow \bullet$
- 7:  $S \rightarrow Bb\bullet Ba$ 
  - $B \rightarrow \bullet$
- 8:  $S \rightarrow AaA\bullet b$
- 9:  $S \rightarrow BbB\bullet a$
- 10:  $S \rightarrow AaAb\bullet$
- 11:  $S \rightarrow BbBa\bullet$

$FOLLOW(A) = FOLLOW(B) = \{a,b\}$ . There is therefore a reduce-reduce conflict in state 1, so the grammar is not SLR(1).

7. The following LR(0) items are produced for this grammar:

[10 marks]

- 1:  $S' \rightarrow \bullet S\$$ 
  - $S \rightarrow \bullet Xb$
  - $S \rightarrow \bullet Y$
  - $X \rightarrow \bullet aY$
  - $Y \rightarrow \bullet a$
  - $Y \rightarrow \bullet aX$
- 2:  $S' \rightarrow S\bullet\$$
- 3:  $S' \rightarrow S\$ \bullet$
- 4:  $S \rightarrow X\bullet b$
- 5:  $S \rightarrow Xb\bullet$
- 6:  $S \rightarrow Y\bullet$
- 7:  $X \rightarrow a\bullet Y$ 
  - $Y \rightarrow a\bullet$
  - $Y \rightarrow a\bullet X$
  - $Y \rightarrow \bullet a$
  - $Y \rightarrow \bullet aX$
  - $X \rightarrow \bullet aY$
- 8:  $X \rightarrow aY\bullet$
- 9:  $Y \rightarrow aX\bullet$

There is a shift-reduce conflict in state 7, so the grammar is not LR(0).

8. The following LR(1) items are produced for this grammar:

[10 marks]

- 1:  $S \rightarrow \bullet Xb, \$$   
 $S \rightarrow \bullet Y, \$$   
 $X \rightarrow \bullet aY, b$   
 $Y \rightarrow \bullet a, \$$   
 $Y \rightarrow \bullet aX, \$$
- 2:  $S \rightarrow X\bullet b, \$$
- 3:  $S \rightarrow Xb\bullet, \$$
- 4:  $S \rightarrow Y\bullet, \$$
- 5:  $X \rightarrow a\bullet Y, b$   
 $Y \rightarrow a\bullet, \$$   
 $Y \rightarrow a\bullet X, \$$   
 $Y \rightarrow \bullet a, b$   
 $Y \rightarrow \bullet aX, b$   
 $X \rightarrow \bullet aY, \$$
- 6:  $X \rightarrow aY\bullet, b$
- 7:  $Y \rightarrow aX\bullet, \$$
- 8:  $X \rightarrow a\bullet Y, \$$   
 $Y \rightarrow a\bullet, b$   
 $Y \rightarrow a\bullet X, b$   
 $Y \rightarrow \bullet a, \$$   
 $Y \rightarrow \bullet aX, \$$   
 $X \rightarrow \bullet aY, b$
- 9:  $X \rightarrow aY\bullet, \$$
- 10:  $Y \rightarrow aX\bullet, b$

There no conflicts, so the grammar is LR(1).

9. The `bas` attribute of each digit is 8.

[10 marks]

The `pos` attributes of each digit (from left to right) are 2, 1 and 0.

The `val` attributes of each digit (from left to right) are 64, 16 and 3.

The `val` attribute for the whole number is 83.

10. The control flow graph is as follows:

[10 marks]

